

20m High Frequency Compact Laser Distance Sensor Module

KEY PROPERTIES

- Measurement Range:
 - 0.3~20m (indoor)
 - 0.3~12m (outdoor)
- Measurement Frequency: 100Hz (fixed)
- Measurement Accuracy:
 - $\pm 3\text{cm}$ @ $< 6\text{m}$
 - $< 1\%$ @ $> 6\text{m}$
- Wavelength: 905 nm
- Communication Interface: TTL (UART)



FUNCTION

- Start / Stop Measurement
- Baudrate Setting

INTRODUCTION

The GLRF20M100HS is a compact laser rangefinder module that uses dToF technology. It features a high-sensitivity SPAD sensor, enabling a maximum measurement distance of 20 meters indoors and 12 meters outdoors. The TDC architecture design ensures the module maintains a stable measurement frequency of 100Hz. Which uses LGA packaging technology to minimize size and weighs only 1.35g. It includes a locking hole and adhesive backing for easy installation and integration.

The GLRF20M100HS uses a standard TTL (UART) communication interface, allowing users to develop and program their own applications. It is an ideal solution that combines small size, lightweight, and high-frequency ranging capabilities.

SPECIFICATIONS

Technical specifications	
Model Name	GLRF20M100HS
Measurement Range	0.3~20m (indoor) 0.3~12m (outdoor)
Frequency	100Hz (fixed)
Accuracy	≤6m: ±3cm >6m: ≤1%
Optical Design	
Wavelength	905nm
Beam Divergence	2°
Anti-ambient Light	≥12m @ 100KLUX
Communication	
Communication Interface	3.3V TTL (UART)
Baud Rate	9600~921600 bps
Interface Connector	FWF08002-S06B13W5M (TXGA)
Power Consumption	
Input Voltage	DC 3.0~3.6V
Working Current	120mA
Mechanical	
Dimensions	21x15x7.9mm
Weight	1.35g
Environmental	
Operating Temperature	-20°C~50°C
Storage Temperature	-40°C~85°C
ESD Class	Human Body Model (HBM) ESD Level: 2000V (JESD22-A114) Machine Model (MM) ESD Level: 200V (JESD22-A115) Charge Device Model (CDM) ESD Level: 500V (JESD22-C101)



PIN ASSIGNMENT

Pin	Definition	Description
1	3V3	Power supply for laser
2	3V3	Power supply for system
3	UART_TX	Serial port transmitter, TTL_3.3V level
4	UART_RX	Serial port receiver, TTL_3.3V level
5	GND	TTL Ground
6	GND	Power Ground

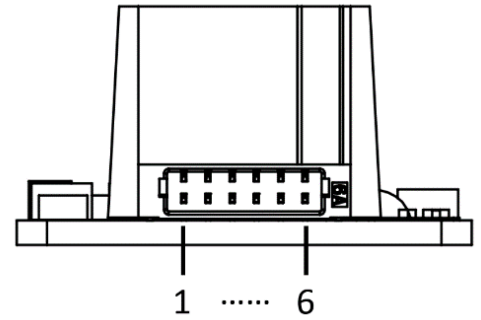
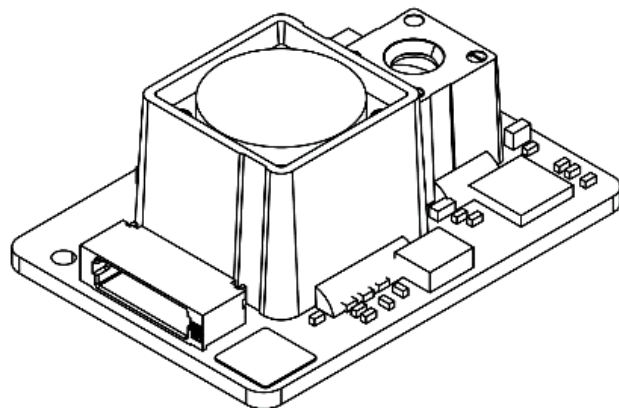
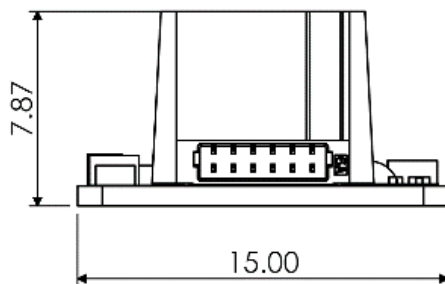
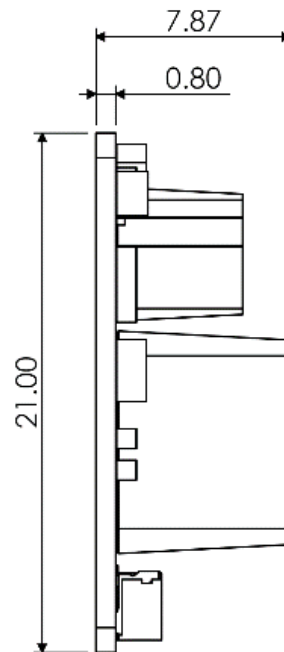
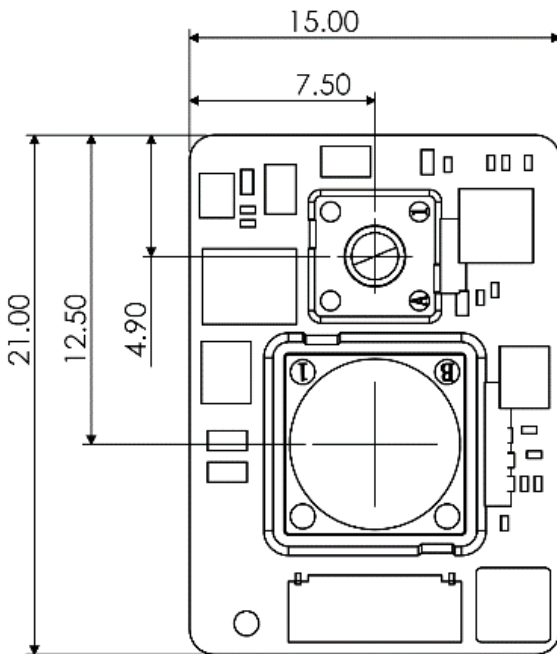
DIMENSIONS

COMMUNICATION

URAT Configuration Parameters

At a default baud rate of 921160 bps, the protocol is set to 8N1, and byte data is in hexadecimal.

- Baud rate: 9600~921160 bps
- Data bits: 8
- Parity bits: None
- Stop bits: 1

Data Frame Format

Head	CMD	Reserve	Length	Data	CRC16
0xA5 0x03 0x20	1 byte	0x00	2 bytes	N byte	2 bytes

- CMD: Command function code, please refer to section 4.3.
- Length: Length of the Data.
- Data: The data content of the data frame.
- CRC16: CRC16 checksum result of all data, with the high byte first and the low byte last.

Command Code List

Command code	Description
0x01	Start Measurement
0x02	Stop Measurement
0x10	Set Baud Rate
0x11	Get Baud Rate



Command Description
Start Measurement

Send					
Head	CMD	Reserve	Length	Data	CRC16
0xA5 0x03 0x20	0x01	0x00	0x00 0x00	0 byte	0x02 0x6E

Receive					
Head	CMD	Reserve	Length	Data	CRC16
0xA5 0x03 0x20	0x01	0x00	0x00 0x0E	14 bytes *	2 bytes

*Data:

byte	Description
0~5	Fixed as 0xFF.
6~7	Distance measurement result (mm).
8~9	Calibration parameters, The measurement results already include the calculation of these parameters, so these two bytes can be ignored.
10~11	Signal intensity, with higher values indicating a stronger received laser reflection signal.
12~13	Background sunlight intensity

* All of the above have the low byte first and the high byte last

* Example: A5 03 20 01 00 00 0E FF FF FF FF FF FF **4B 03** 5E 00 **24 23** 01 00 BB D8

Distance = $0x4B + 0x03 * 256 = 843\text{mm}$

Signal intensity = $0x24 + 0x23 * 256 = 8996$

Background sunlight intensity = $0x01 + 0x00 * 256 = 1$

Stop Measurement

Send					
Head	CMD	Reserve	Length	Data	CRC16
0xA5 0x03 0x20	0x02	0x00	0x00 0x00	0 byte	0x46 0x6E

Receive					
Head	CMD	Reserve	Length	Data	CRC16
0xA5 0x03 0x20	0x02	0x00	0x00 0x01	0x00	0x7C 0xC6



Set Baud Rate

Send					
Head	CMD	Reserve	Length	Data	CRC16
0xA5 0x03 0x20	0x10	0x00	0x00 0x01	Baudrate*	2 bytes
*Baudrate: 0x00 is 9600 bps (CRC = 0x7E 0x7E) 0x01 is 14400 bps (CRC = 0xBF 0xBF) 0x02 is 19200 bps (CRC = 0xBE 0xFF) 0x03 is 38400 bps (CRC = 0x7E 0x3E) 0x04 is 43000 bps (CRC = 0xBC 0x7F) 0x05 is 57600 bps (CRC = 0x7C 0xBE) 0x06 is 76800 bps (CRC = 0x7D 0xFE) 0x07 is 115200 bps (CRC = 0xBD 0x3F) 0x08 is 128000 bps (CRC = 0xB9 0x7F) 0x09 is 230400 bps (CRC = 0x79 0xBE) 0x0A is 256000 bps (CRC = 0x78 0xFE) 0x0B is 460800 bps (CRC = 0xB8 0x3F) 0x0C is 921600 bps (CRC = 0x7A 0x7E)					

Get Baud Rate

Send					
Head	CMD	Reserve	Length	Data	CRC16
0xA5 0x03 0x20	0x11	0x00	0x00 0x00	0 byte	0xC2 0x6A

Receive					
Head	CMD	Reserve	Length	Data	CRC16
0xA5 0x03 0x20	0x11	0x00	0x00 0x04	4 bytes	2 bytes
*Data: Baudrate=Data[0]*16777216 + Data[1]*65536 + Data[2]*256 + Data[3] Example: When Data is 00 0E 10 00, means baudrate is 921600bps.					

